

DEWALT®

www.DEWALT.com

DWS713

Fig. A

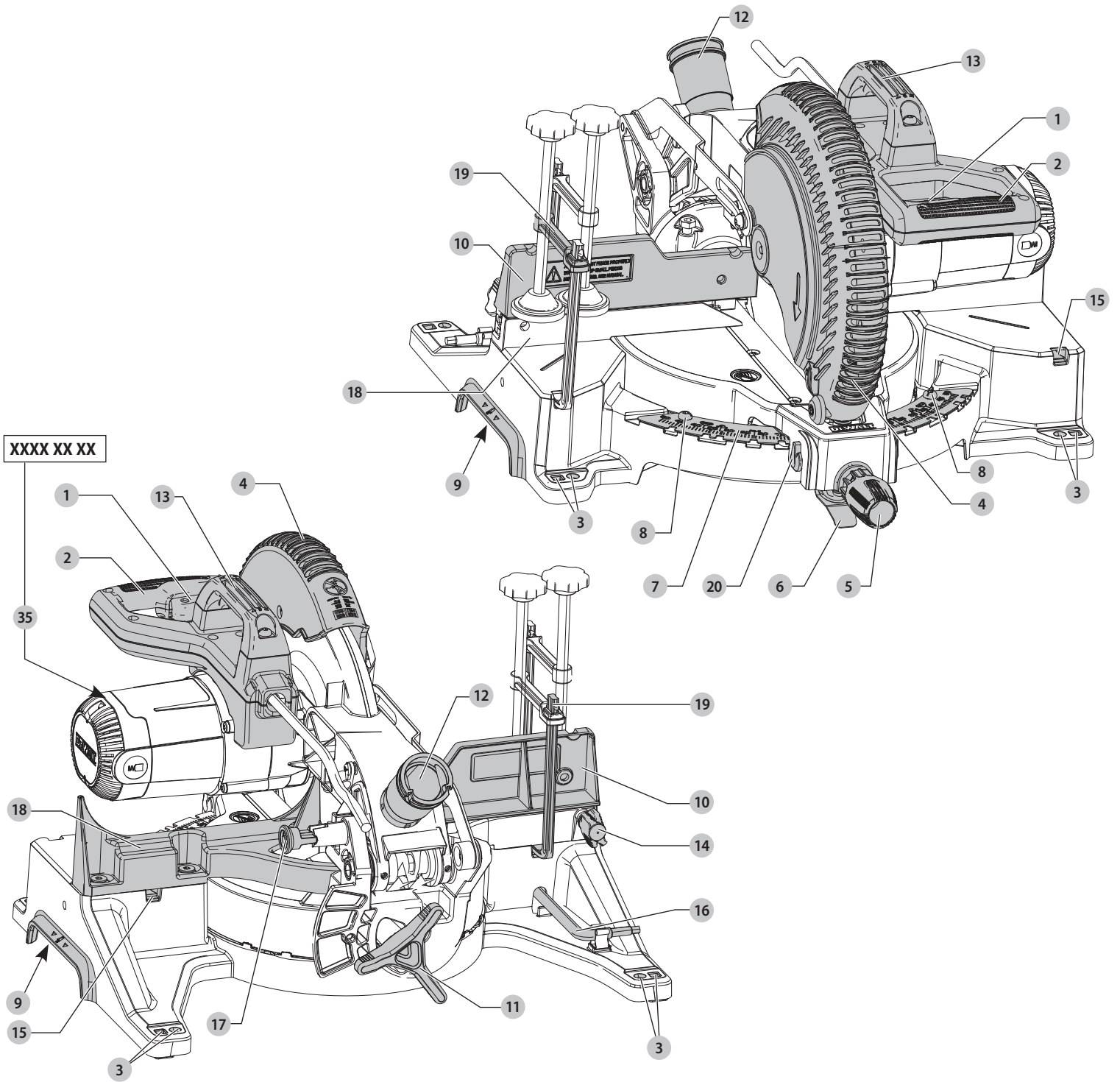

Fig. B

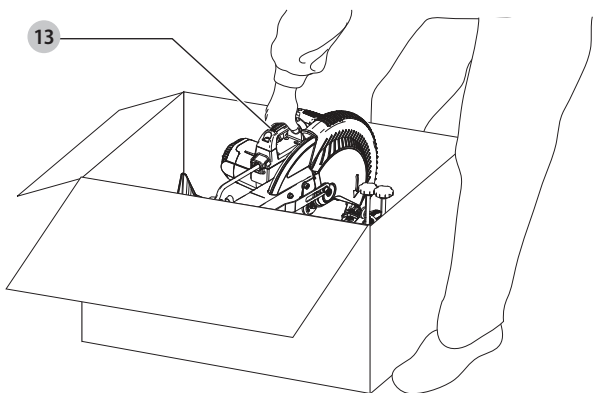

Fig. C

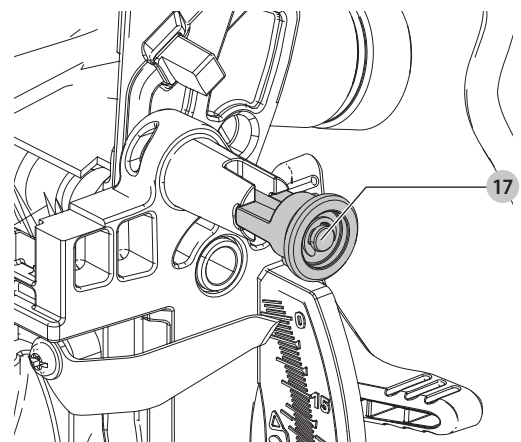

Fig. D

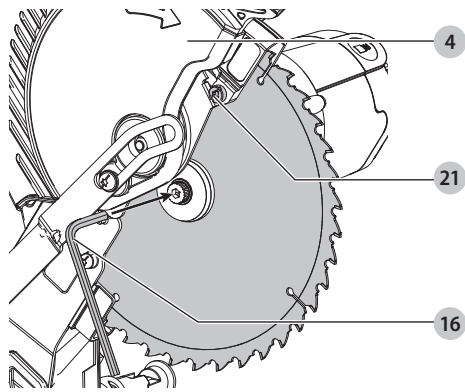

Fig. E

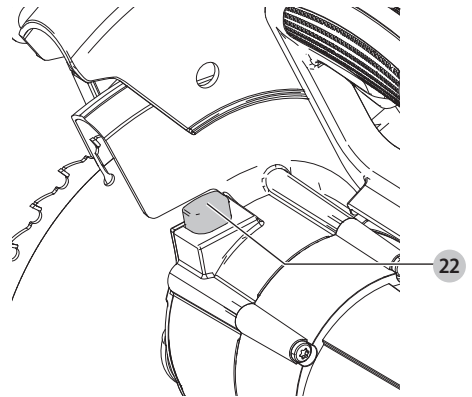

Fig. F

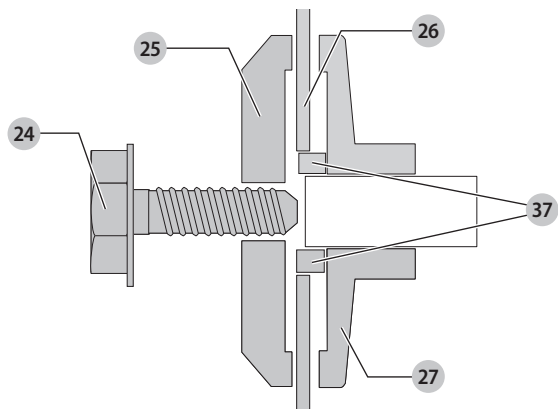

Fig. G

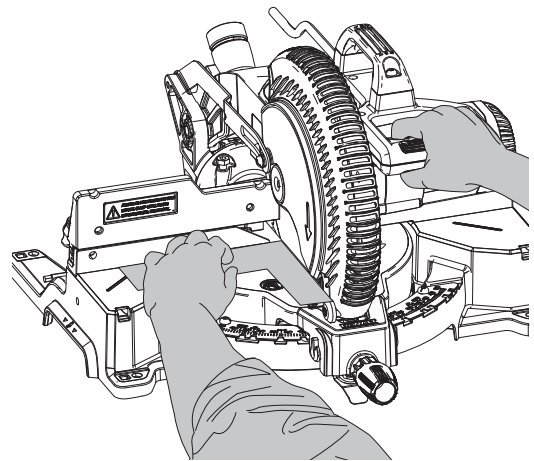

Fig. H

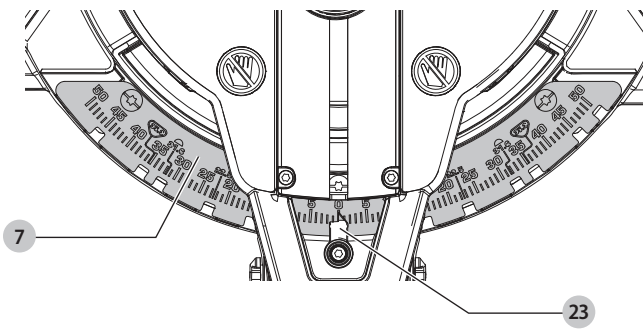

Fig. I

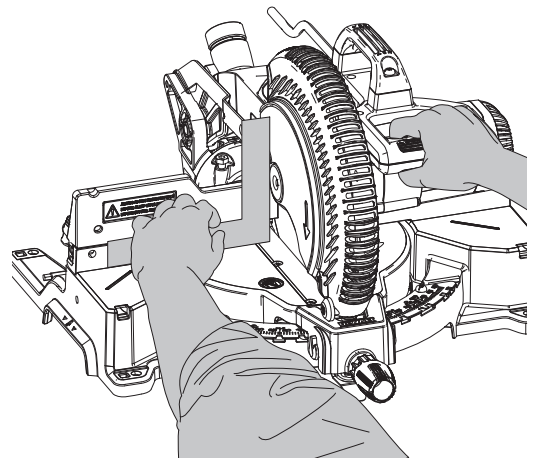

Fig. J

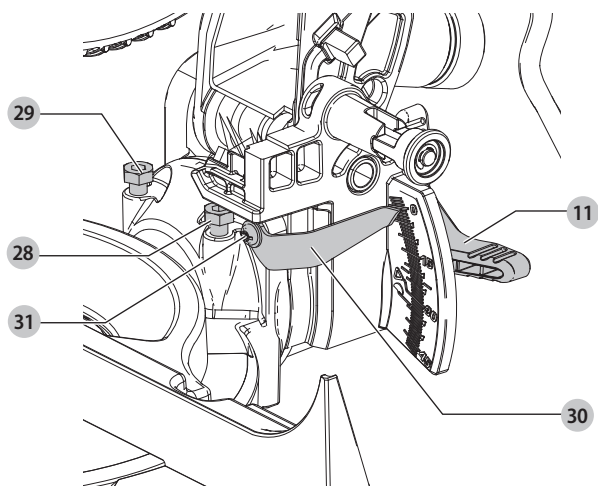

Fig. K

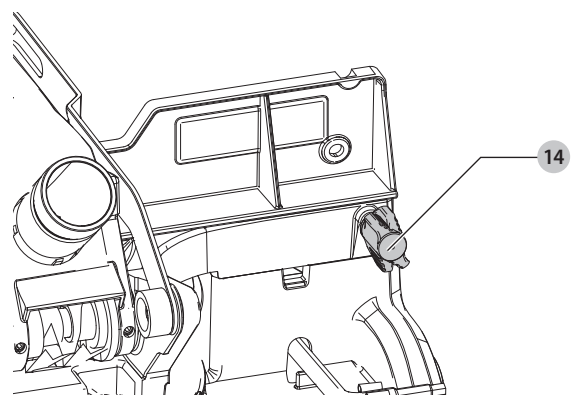

Fig. L

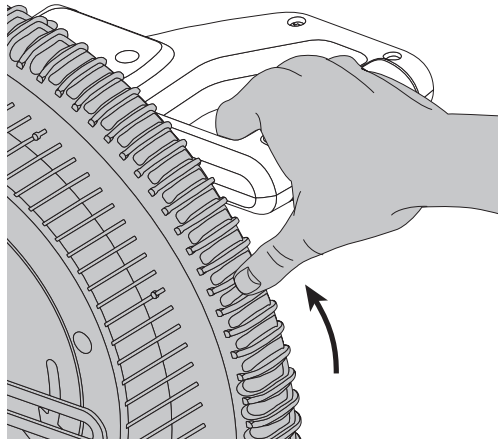

Fig. M1, M2

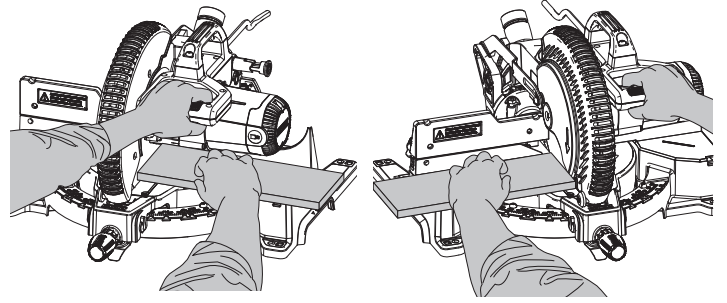

Fig. M3, M4

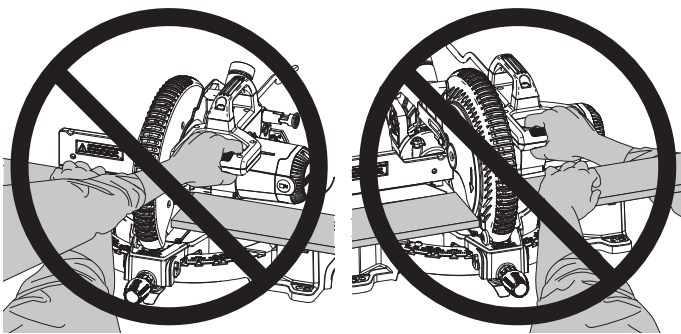

Fig. N

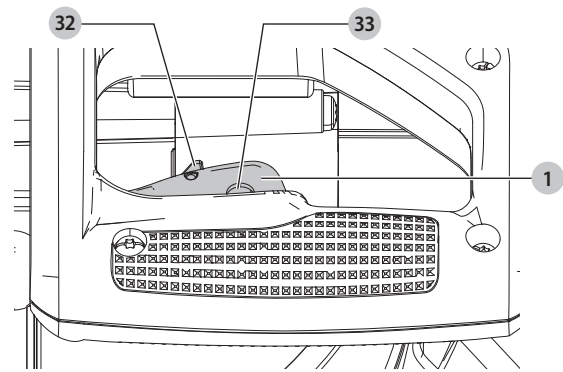

Fig. O

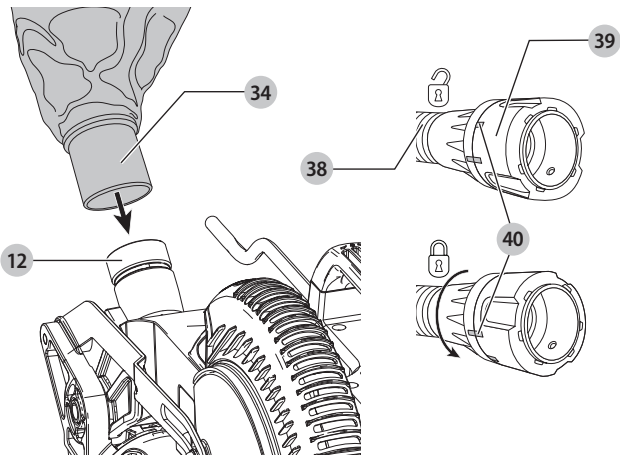

Fig. P

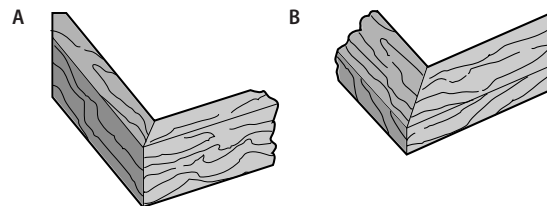

Fig. Q

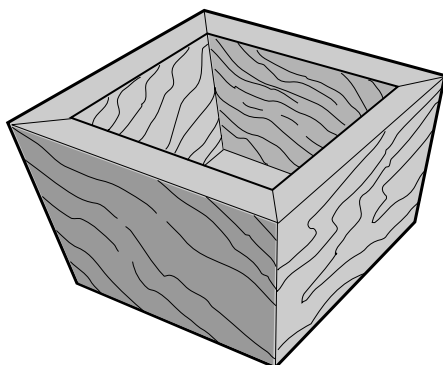

Fig. R

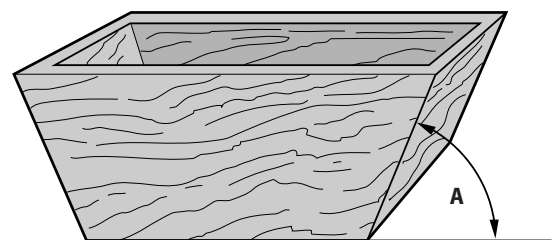

Fig. S

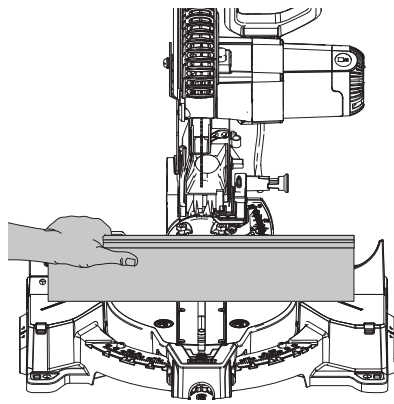

Fig. T

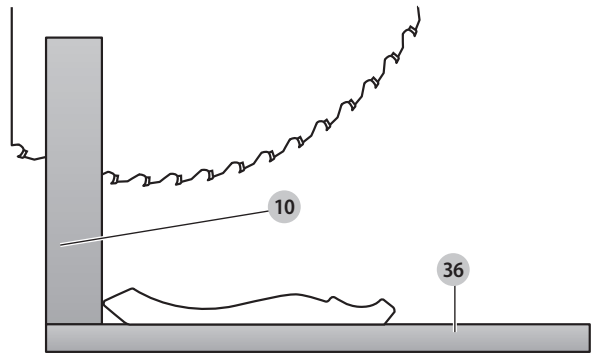

Fig. U

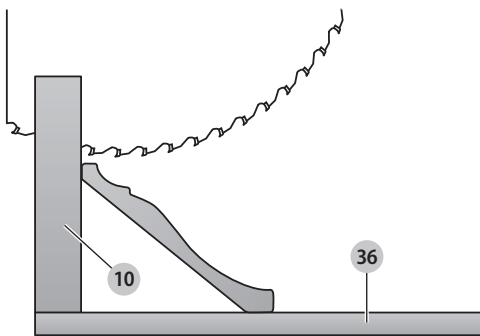

Fig. V

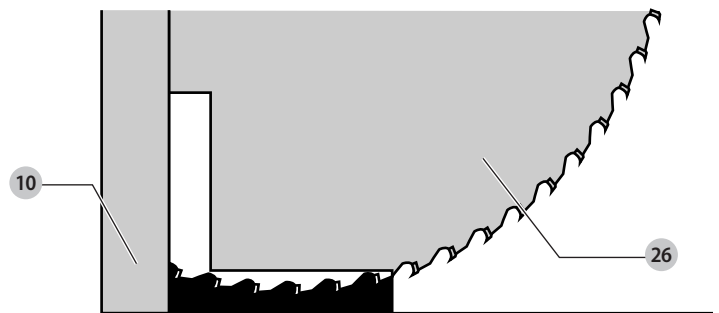

Fig. W

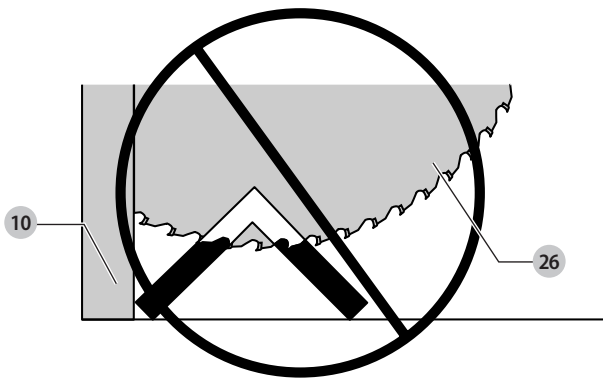

Fig. X

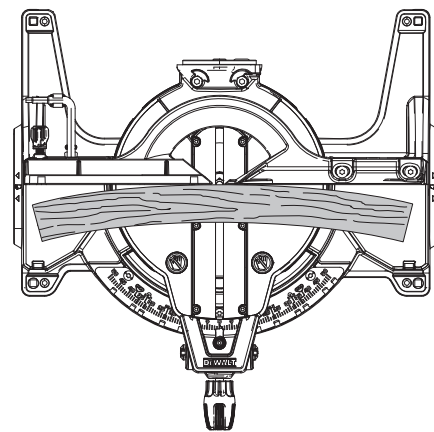
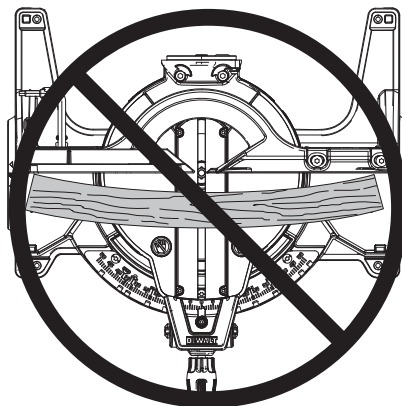

Fig. Y



254 mm COMPOUND MITRE SAW

DWS713

Congratulations!

You have chosen a DEWALT tool. Years of experience, thorough product development and innovation make DEWALT one of the most reliable partners for professional power tool users.

Technical Data

		DWS713
Voltage	V	230
Type		20
Power input	W	1600
Blade diameter	mm	254
Max. blade speed	min ⁻¹	5000
Max. cross-cut capacity 90°	mm	155
Max. mitre capacity 45°	mm	107
Max. depth of cut 90°	mm	89
Max. depth of bevel cross-cut 45°	mm	58
Baseboard vertically against fence		
Max. Height	mm	108
Max. Width	mm	16
Mitre (max. positions)		
	left	50°
	right	50°
Bevel (max. positions)		
	left	48°
	right	3°
0° mitre		
Resulting width at max. height 89 mm	mm	89
Resulting height at max. width 155 mm	mm	32
45° mitre		
Resulting width at max. height 89 mm	mm	61
Resulting height at max. width 107 mm	mm	32
45° bevel		
Resulting width at max. height 58 mm	mm	89
Resulting height at max. width 155 mm	mm	19
31.6° mitre, 33.9° bevel		
Resulting height at max. width 133 mm	mm	23
Automatic blade brake time	s	< 10.0
Weight	kg	14

The vibration emission level given in this information sheet has been measured in accordance with a standardised test given in EN62841 and may be used to compare one tool with another. It may be used for a preliminary assessment of exposure.

WARNING: The declared vibration emission level represents the main applications of the tool. However if the tool is used for different applications, with different accessories or poorly maintained, the vibration emission may differ. This may significantly increase the exposure level over the total working period.

An estimation of the level of exposure to vibration should also take into account the times when the tool is switched off or when it is running but not actually doing the job. This may significantly reduce the exposure level over the total working period.

Identify additional safety measures to protect the operator from the effects of vibration such as: maintain the tool and the accessories, keep the hands warm, organisation of work patterns.

WARNING: To reduce the risk of injury, read the instruction manual.

Definitions: Safety Guidelines

The definitions below describe the level of severity for each signal word. Please read the manual and pay attention to these symbols.

DANGER: Indicates an imminently hazardous situation which, if not avoided, **will** result in **death or serious injury**.

WARNING: Indicates a potentially hazardous situation which, if not avoided, **could** result in **death or serious injury**.

CAUTION: Indicates a potentially hazardous situation which, if not avoided, **may** result in **minor or moderate injury**.

NOTICE: Indicates a practice **not related to personal injury** which, if not avoided, **may** result in **property damage**.

⚡ Denotes risk of electric shock.

🔥 Denotes risk of fire.

General Power Tool Safety Warnings

WARNING: Read all safety warnings, instructions, illustrations and specifications provided with this power tool. Failure to follow all instructions listed below may result in electric shock, fire and/or serious injury.

SAVE ALL WARNINGS AND INSTRUCTIONS FOR FUTURE REFERENCE

The term "power tool" in the warnings refers to your mains-operated (corded) power tool or battery-operated (cordless) power tool.

1) Work Area Safety

- Keep work area clean and well lit. Cluttered or dark areas invite accidents.
- Do not operate power tools in explosive atmospheres, such as in the presence of flammable liquids, gases or dust. Power tools create sparks which may ignite the dust or fumes.
- Keep children and bystanders away while operating a power tool. Distractions can cause you to lose control.

2) Electrical Safety

- Power tool plugs must match the outlet. Never modify the plug in any way. Do not use any adapter plugs with earthed (grounded) power tools. Unmodified plugs and matching outlets will reduce risk of electric shock.
- Avoid body contact with earthed or grounded surfaces such as pipes, radiators, ranges and refrigerators. There is an increased risk of electric shock if your body is earthed or grounded.
- Do not expose power tools to rain or wet conditions. Water entering a power tool will increase the risk of electric shock.
- Do not abuse the cord. Never use the cord for carrying, pulling or unplugging the power tool. Keep cord away from heat, oil, sharp edges or moving parts. Damaged or entangled cords increase the risk of electric shock.
- When operating a power tool outdoors, use an extension cord suitable for outdoor use. Use of a cord suitable for outdoor use reduces the risk of electric shock.
- If operating a power tool in a damp location is unavoidable, use a residual current device (RCD) protected supply. Use of an RCD reduces the risk of electric shock.

3) Personal Safety

- Stay alert, watch what you are doing and use common sense when operating a power tool. Do not use a power tool while you are tired or under the influence of drugs, alcohol or medication. A moment of inattention while operating power tools may result in serious personal injury.
- Use personal protective equipment. Always wear eye protection. Protective equipment such as dust mask, non-skid safety shoes, hard hat, or hearing protection used for appropriate conditions will reduce personal injuries.
- Prevent unintentional starting. Ensure the switch is in the off-position before connecting to power source and/or battery pack, picking up or carrying the tool. Carrying power tools with your finger on the switch or energizing power tools that have the switch on invites accidents.
- Remove any adjusting key or wrench before turning the power tool on. A wrench or a key left attached to a rotating part of the power tool may result in personal injury.
- Do not overreach. Keep proper footing and balance at all times. This enables better control of the power tool in unexpected situations.
- Dress properly. Do not wear loose clothing or jewelry. Keep your hair, clothing and gloves away from moving parts. Loose clothes, jewelry or long hair can be caught in moving parts.
- If devices are provided for the connection of dust extraction and collection facilities, ensure these are connected and properly used. Use of dust collection can reduce dust-related hazards.
- Do not let familiarity gained from frequent use of tools allow you to become complacent and ignore tool safety principles. A careless action can cause severe injury within a fraction of a second.

4) Power Tool Use and Care

- Do not force the power tool. Use the correct power tool for your application. The correct power tool will do the job better and safer at the rate for which it was designed.
- Do not use the power tool if the switch does not turn it on and off. Any power tool that cannot be controlled with the switch is dangerous and must be repaired.
- Disconnect the plug from the power source and/or the battery pack, if detachable, from the power tool before making any adjustments, changing accessories, or storing power tools. Such preventive safety measures reduce the risk of starting the power tool accidentally.
- Store idle power tools out of the reach of children and do not allow persons unfamiliar with the power tool or these instructions to operate the power tool. Power tools are dangerous in the hands of untrained users.
- Maintain power tools. Check for misalignment or binding of moving parts, breakage of parts and any other condition that may affect the power tool's operation. If damaged, have the power tool repaired before use. Many accidents are caused by poorly maintained power tools.
- Keep cutting tools sharp and clean. Properly maintained cutting tools with sharp cutting edges are less likely to bind and are easier to control.

- g) **Use the power tool, accessories and tool bits, etc. in accordance with these instructions, taking into account the working conditions and the work to be performed.** Use of the power tool for operations different from those intended could result in a hazardous situation.
- h) **Keep handles and grasping surfaces dry, clean and free from oil and grease.** Slippery handles and grasping surfaces do not allow for safe handling and control of the tool in unexpected situations.





5) Service

- a) **Have your power tool serviced by a qualified repair person using only identical replacement parts.** This will ensure that the safety of the power tool is maintained.

Safety Instructions for Mitre Saws

- a) **Mitre saws are intended to cut wood or wood-like products, they cannot be used with abrasive cut-off wheels for cutting ferrous material such as bars, rods, studs, etc.** Abrasive dust causes moving parts such as the lower guard to jam. Sparks from abrasive cutting will burn the lower guard, the kerf insert and other plastic parts.
- b) **Use clamps to support the workpiece whenever possible. If supporting the workpiece by hand, you must always keep your hand at least 100 mm from either side of the saw blade. Do not use this saw to cut pieces that are too small to be securely clamped or held by hand.** If your hand is placed too close to the saw blade, there is an increased risk of injury from blade contact.
- c) **The workpiece must be stationary and clamped or held against both the fence and the table. Do not feed the workpiece into the blade or cut "freehand" in any way.** Unrestrained or moving workpieces could be thrown at high speeds, causing injury.
- d) **Push the saw through the workpiece. Do not pull the saw through the workpiece. To make a cut, raise the saw head and pull it out over the workpiece without cutting, start the motor, press the saw head down and push the saw through the workpiece.** Cutting on the pull stroke is likely to cause the saw blade to climb on top of the workpiece and violently throw the blade assembly towards the operator.
- e) **Never cross your hand over the intended line of cutting either in front or behind the saw blade.** Supporting the workpiece "cross handed" i.e. holding the workpiece to the right of the saw blade with your left hand or vice versa is very dangerous.
- f) **Do not reach behind the fence with either hand closer than 100 mm from either side of the saw blade, to remove wood scraps, or for any other reason while the blade is spinning.** The proximity of the spinning saw blade to your hand may not be obvious and you may be seriously injured.
- g) **Inspect your workpiece before cutting. If the workpiece is bowed or warped, clamp it with the outside bowed face toward the fence. Always make certain that there is no gap between the workpiece, fence and table along the line of the cut.** Bent or warped workpieces can twist or shift and may cause binding on the spinning saw blade while cutting. There should be no nails or foreign objects in the workpiece.
- h) **Do not use the saw until the table is clear of all tools, wood scraps, etc., except for the workpiece.** Small debris or loose pieces of wood or other objects that contact the revolving blade can be thrown with high speed.
- i) **Cut only one workpiece at a time.** Stacked multiple workpieces cannot be adequately clamped or braced and may bind on the blade or shift during cutting.
- j) **Ensure the mitre saw is mounted or placed on a level, firm work surface before use.** A level and firm work surface reduces the risk of the mitre saw becoming unstable.
- k) **Plan your work. Every time you change the bevel or mitre angle setting, make sure the adjustable fence is set correctly to support the workpiece and will not interfere with the blade or the guarding system.** Without turning the tool "ON" and with no workpiece on the table, move the saw blade through a complete simulated cut to assure there will be no interference or danger of cutting the fence.
- l) **Provide adequate support such as table extensions, saw horses, etc. for a workpiece that is wider or longer than the table top.** Workpieces longer or wider than the mitre saw table can tip if not securely supported. If the cut-off piece or workpiece tips, it can lift the lower guard or be thrown by the spinning blade.
- m) **Do not use another person as a substitute for a table extension or as additional support.** Unstable support for the workpiece can cause the blade to bind or the workpiece to shift during the cutting operation pulling you and the helper into the spinning blade.
- n) **The cut-off piece must not be jammed or pressed by any means against the spinning saw blade.** If confined, i.e. using length stops, the cut-off piece could get wedged against the blade and thrown violently.
- o) **Always use a clamp or a fixture designed to properly support round material such as rods or tubing.** Rods have a tendency to roll while being cut, causing the blade to "bite" and pull the work with your hand into the blade.
- p) **Let the blade reach full speed before contacting the workpiece.** This will reduce the risk of the workpiece being thrown.
- q) **If the workpiece or blade becomes jammed, turn the mitre saw off. Wait for all moving parts to stop and disconnect the plug from the power source and/or remove the battery pack. Then work to free the jammed material.** Continued sawing with a jammed workpiece could cause loss of control or damage to the mitre saw.
- r) **After finishing the cut, release the switch, hold the saw head down and wait for the blade to stop before removing the cut-off piece.** Reaching with your hand near the coasting blade is dangerous.
- s) **Hold the handle firmly when making an incomplete cut or when releasing the switch before the saw head is completely in the down position.** The braking action of the saw may cause the saw head to be suddenly pulled downward, causing a risk of injury.

Additional Safety Rules for Mitre Saws

-  **WARNING:** Do not connect to the mains power supply into the unit until complete instructions are read and understood.
- **DO NOT OPERATE THIS MACHINE** until it is completely assembled and installed according to the instructions. A machine incorrectly assembled can cause serious injury.
 - **OBTAIN ADVICE** from your supervisor, instructor, or another qualified person if you are not thoroughly familiar with the operation of this machine. Knowledge is safety.
 - **MAKE CERTAIN** the blade rotates in the correct direction. The teeth on the blade should point in the direction of rotation as marked on the saw.
 - **TIGHTEN ALL CLAMP HANDLES,** knobs and levers prior to operation. Loose clamps can cause parts or the workpiece to be thrown at high speeds.
 - **BE SURE** all blade and blade clamps are clean, recessed sides of blade clamps are against blade and arbour screw is tightened securely. Loose or improper blade clamping may result in damage to the saw and possible personal injury.
 - **DO NOT OPERATE ON ANYTHING OTHER THAN THE DESIGNATED VOLTAGE** for the saw. Overheating, damage to the tool and personal injury may occur.
 - **DO NOT WEDGE ANYTHING AGAINST THE FAN** to hold the motor shaft. Damage to tool and possible personal injury may occur.
 - **NEVER CUT METALS** or masonry. Either of these can cause the carbide tips to fly off the blade at high speeds causing serious injury.
 - **NEVER HAVE ANY PART OF YOUR BODY IN LINE WITH THE PATH OF THE SAW BLADE.** Personal injury will occur.
 - **NEVER APPLY BLADE LUBRICANT TO A RUNNING BLADE.** Applying lubricant could cause your hand to move into the blade resulting in serious injury.
 - **DO NOT** place either hand in the blade area when the saw is connected to the power source. Inadvertent blade activation may result in serious injury.
 - **NEVER REACH AROUND OR BEHIND THE SAW BLADE.** A blade can cause serious injury.
 - **DO NOT REACH UNDERNEATH THE SAW** unless it is unplugged and turned off. Contact with saw blade may cause personal injury.
 - **SECURE THE MACHINE TO A STABLE SUPPORTING SURFACE.** Vibration can possibly cause the machine to slide, walk, or tip over, causing serious injury.
 - **USE ONLY CROSSCUT SAW BLADES** recommended for mitre saws. For best results, do not use carbide tipped blades with hook angles in excess of 7 degrees. Do not use blades with deep gullets. These can deflect and contact the guard, and can cause damage to the machine and/or serious injury.
 - **USE ONLY BLADES OF THE CORRECT SIZE AND TYPE** specified for this tool to prevent damage to the machine and/or serious injury (complying with EN847-1).
 - **INSPECT BLADE FOR CRACKS** or other damage prior to operation. A cracked or damaged blade can come apart and pieces can be thrown at high speeds, causing serious injury. Replace cracked or damaged blades immediately. Observe the maximum speed marked on the saw blade.
 - **CLEAN THE BLADE AND BLADE CLAMPS** prior to operation. Cleaning the blade and blade clamps allows you to check for any damage to the blade or blade clamps. A cracked or damaged blade or blade clamp can come apart and pieces can be thrown at high speeds, causing serious injury.
 - **DO NOT USE WARPED BLADES.** Check to see if the blade runs true and is free from vibration. A vibrating blade can cause damage to the machine and/or serious injury.
 - **DO NOT** use lubricants or cleaners (particularly spray or aerosol) in the vicinity of the plastic guard. The polycarbonate material used in the guard is subject to attack by certain chemicals.
 - **KEEP GUARD IN PLACE** and in working order.
 - **ALWAYS USE THE KERF PLATE AND REPLACE THIS PLATE WHEN DAMAGED.** Small chip accumulation under the saw may interfere with the saw blade or may cause instability of workpiece when cutting.
 - **USE ONLY BLADE CLAMPS SPECIFIED FOR THIS TOOL** to prevent damage to the machine and/or serious injury.
 - **MAKE SURE** to use the correct saw blade for the material to be cut.
 - **CLEAN THE MOTOR AIR SLOTS** of chips and sawdust. Clogged motor air slots can cause the machine to overheat, damaging the machine and possibly causing a short which could cause serious injury.
 - **NEVER LOCK THE SWITCH IN THE "ON" POSITION.** Severe personal injury may result.
 - **NEVER STAND ON TOOL.** Serious injury could occur if the tool is tipped or if the cutting tool is unintentionally contacted.
-  **WARNING:** Cutting plastics, sap coated wood, and other materials may cause melted material to accumulate on the blade tips and the body of the saw blade, increasing the risk of blade overheating and binding while cutting.
-  **WARNING:** Always wear proper personal hearing protection. Under some conditions and duration of use, noise from this product may contribute to hearing loss. Be aware of the following factors influencing exposure to noise:
- Use saw blades designed to reduce the emitted noise,
 - Use only well sharpened saw blades, and
 - Use specifically designed noise-reduction saw blades.
-  **WARNING:** ALWAYS use safety glasses. Everyday eyeglasses are NOT safety glasses. Also use face or dust mask if cutting operation is dusty.
-  **WARNING:** Use of this tool can generate and/or disperse dust, which may cause serious and permanent respiratory or other injury.

WARNING: Some dust created by power sanding, sawing, grinding, drilling, and other construction activities contains chemicals known to cause cancer, birth defects or other reproductive harm. Some examples of these chemicals are:

- lead from lead-based paints,
- crystalline silica from bricks and cement and other masonry products, and
- arsenic and chromium from chemically-treated lumber.

Your risk from these exposures varies, depending on how often you do this type of work. To reduce your exposure to these chemicals: work in a well ventilated area, and work with approved safety equipment, such as those dust masks that are specially designed to filter out microscopic particles.

• **Avoid prolonged contact with dust from power sanding, sawing, grinding, drilling, and other construction activities.** Wear protective clothing and wash exposed areas with soap and water. Allowing dust to get into your mouth, eyes, or lay on the skin may promote absorption of harmful chemicals.

WARNING: Use of this tool can generate and/or disperse dust, which may cause serious and permanent respiratory or other injury. Always use approved respiratory protection appropriate for the dust exposure.

Residual Risks

The following risks are inherent to the use of saws:

- Injuries caused by touching the rotating parts.

In spite of the application of the relevant safety regulations and the implementation of safety devices, certain residual risks cannot be avoided. These are:

- Impairment of hearing.
- Risk of accidents caused by the uncovered parts of the rotating saw blade.
- Risk of injury when changing the blade.
- Risk of squeezing fingers when opening the guards.
- Health hazards caused by breathing dust developed when sawing wood, especially oak, beech and MDF.

The following factors increase the risk of breathing problems:

- No dust extractor connected when sawing wood.
- Insufficient dust extraction caused by uncleaned exhaust filters.

Electrical Safety

The electric motor has been designed for one voltage only. Always check that the power supply corresponds to the voltage on the rating plate.



Your DeWALT tool is double insulated in accordance with EN60745; therefore no earth wire is required.



WARNING: We recommend the use of a residual current device with a residual current rating of 30mA or less.



WARNING: 115 V units have to be operated via a fail-safe isolating transformer with an earth screen between the primary and secondary winding.

If the supply cord is damaged, it must be replaced by a specially prepared cord available through the DeWALT service organisation.

Mains Plug Replacement (U.K. & Ireland Only)

If a new mains plug needs to be fitted:

- Safely dispose of the old plug.
- Connect the brown lead to the live terminal in the plug.
- Connect the blue lead to the neutral terminal.



WARNING: No connection is to be made to the earth terminal.

Follow the fitting instructions supplied with good quality plugs. Recommended fuse: 13 A.

Using an Extension Cable

If an extension cable is required, use an approved 3-core extension cable suitable for the power input of this tool (see **Technical Data**). The minimum conductor size is 1.5 mm²; the maximum length is 30 m.

When using a cable reel, always unwind the cable completely.

Package Contents

The package contains:

- 1 Mitre saw
- 1 6 mm hex wrench
- 1 Saw blade
- 1 Dustbag
- 1 Material clamp
- 1 Instruction manual
- Check for damage to the tool, parts or accessories which may have occurred during transport.
- Take the time to thoroughly read and understand this manual prior to operation.

Markings on Tool

The following pictograms are shown on the tool:



Read instruction manual before use.



Wear ear protection.



Wear eye protection.



Keep hands away from blade.



Visible radiation. Do not stare into light.

Date Code Position (Fig. A)

The date code **35**, which also includes the year of manufacture, is printed into the housing.

Example:

2018 XX XX

Year of Manufacture

Description (Fig. A)



WARNING: Never modify the power tool or any part of it. Damage or personal injury could result.

- | | | |
|----------------------|----------------------|----------------------------|
| 1 Trigger switch | 8 Mitre scale screws | 15 Clamp mounting holes |
| 2 Operating handle | 9 Hand indentations | 16 6 mm hex wrench |
| 3 Mounting holes | 10 Sliding fence | 17 Head lock knob |
| 4 Lower guard | 11 Bevel lock knob | 18 Base fence |
| 5 Mitre lock knob | 12 Dust port | 19 Vertical material clamp |
| 6 Mitre detent latch | 13 Carrying handle | 20 Mitre detent override |
| 7 Mitre scale | 14 Fence lock knob | |

Intended Use

Your DeWALT DWS713 compound mitre saw has been designed for professional wood cutting applications. When using the appropriate saw blades, sawing aluminium profiles and plastic is also possible.

DO NOT use under wet conditions or in the presence of flammable liquids or gases.

This mitre saw is a professional power tool.

DO NOT let children come into contact with the tool. Supervision is required when inexperienced operators use this tool.

- **Young children and the infirm.** This appliance is not intended for use by young children or infirm persons without supervision.
- This product is not intended for use by persons (including children) suffering from diminished physical, sensory or mental abilities; lack of experience, knowledge or skills unless they are supervised by a person responsible for their safety. Children should never be left alone with this product.

Specifications

Drive

230 Volt motor
1600 Watts
5000 RPM
Cut helical gears with roller and ball bearings
Carbide tooth blade
Automatic electric brake

Familiarization (Fig. A, B)

Your mitre saw is fully assembled in the carton. Open the box and lift the saw out by the convenient carrying handle **13**, as shown in Figure B.

Place the saw on a smooth, flat surface such as a workbench or strong table.

Examine Figure A to become familiar with the saw and its various parts. The section on adjustments will refer to these terms and you must know what and where the parts are.



CAUTION: Pinch Hazard. To reduce the risk of injury, keep thumb underneath the handle when pulling the handle down. The lower guard will move up as the handle is pulled down which could cause pinching. The handle is placed close to the guard for special cuts.

Press down lightly on the operating handle **2** and loosen the head lock knob **17**. Gently release the downward pressure and allow the arm to rise to its full height. Use the lock down pin when carrying the saw from one place to another. Always use the carrying handle **13** to transport the saw or the hand indentations **9** shown in Figure A.

Bench Mounting (Fig. A)

Mounting holes **3** are provided in all four feet to facilitate bench mounting, as shown in Figure A. (Two different sized holes are provided to accommodate different sizes of screws. Use either hole, it is not necessary to use both.) Always mount your saw firmly to prevent movement. To enhance the tool's portability, it can be mounted to a piece of 12.7 mm or thicker plywood which can then be clamped to your work support or moved to other job sites and re-clamped.

NOTE: If you elect to mount your saw to a piece of plywood, make sure that the mounting screws don't protrude from the bottom of the wood. The plywood must sit flush on the work support. When clamping the saw to any work surface, clamp only on the clamping bosses where the mounting screw holes are located. Clamping at any other point will surely interfere with the proper operation of the saw.

CAUTION: To prevent binding and inaccuracy, be sure the mounting surface is not warped or otherwise uneven. If the saw rocks on the surface place a thin piece of material under one saw foot until the saw sits firmly on the mounting surface.

Transporting the Saw (Fig. A, C)

WARNING: To reduce the risk of serious personal injury, turn off the tool and disconnect it from the power source before attempting to move it, change accessories or make any adjustments.

WARNING: To reduce the risk of serious personal injury, ALWAYS lock the mitre lock knob, bevel lock handle, head lock knob, and fence adjustment knob before transporting saw.

In order to conveniently carry the mitre saw from place to place, a carrying handle **13** has been included on the top of the saw arm and hand indentations **9** in the base, as shown in Figure A. To transport the saw, lower the arm and tighten the head lock knob **17** shown in Figure C.

ASSEMBLY AND ADJUSTMENTS

WARNING: To reduce the risk of serious personal injury, turn tool off and disconnect tool from power source before making any adjustments or removing/installing attachments or accessories. Be sure the trigger switch is in the OFF position. An accidental start-up can cause injury.

Changing or Installing a New Saw Blade (Fig. D–F)

WARNING: To reduce the risk of serious personal injury, turn off the tool and disconnect it from the power source before attempting to move it, change accessories or make any adjustments.

WARNING: When mounting the saw blade, wear protective gloves. Danger of injury when touching the saw blade.

CAUTION:

- Never depress the spindle lock button while the blade is under power or coasting.
- Do not cut ferrous metal (containing iron or steel) or masonry or fiber cement product with this mitre saw.

Removing the Blade

- Unplug the saw.
- Raise the arm to the upper position and raise the lower guard **4** as far as possible.
- Loosen, but do not remove guard bracket screw **21** until the bracket can be raised far enough to access the blade screw. Lower guard will remain raised due to the position of the guard bracket screw.
- Depress the spindle lock button **22** while carefully rotating the saw blade by hand until the lock engages.
- Keeping the button depressed, use the other hand and the 6 mm hex wrench **16** provided to loosen the blade screw **24**. (Turn clockwise, left-hand threads.)
- Remove the blade screw **24**, outer blade clamp **25**, and blade **26**. The inner blade clamp **27**, and if used, the 25.4 mm blade adapter **37**, may be left on the spindle.

NOTE: For blades with a blade hole of 15.88 mm, the 25.4 mm blade adapter is not used.

Installing a Blade

- Unplug the saw.
- With the arm raised, the lower guard held open and the guard bracket, place the blade **26** on the spindle against the inner blade clamp **27** with the teeth at the bottom of the blade pointing toward the back of the saw.
- Assemble the outer blade clamp **25** onto the spindle.
- Install the blade screw **24** and, engaging the spindle lock, tighten the screw firmly with the 6 mm hex wrench provided. (Turn counterclockwise, left-hand threads.)
- Return the guard bracket to its original position and firmly tighten the guard bracket screw **21** to hold bracket in place.

WARNING:

- The guard bracket must be returned to its original position and the screw tightened before activating the saw.
- Failure to do so may allow the guard to contact the spinning saw blade resulting in damage to the saw and severe personal injury.

Mitre Scale Adjustment (Fig. A, G)

Place a square against the saw's fence and blade. (Do not touch the tips of the blade teeth with the square. To do so will cause an inaccurate measurement.) Unlock mitre lock knob **5** and swing the mitre arm until the mitre detent locks it at the 0° mitre position. Do not lock mitre lock knob. If the saw blade is not exactly perpendicular to the base fence **18**, loosen the three mitre scale screws **8** that hold the mitre scale **7** to the base and move the scale/mitre arm assembly left or right until the blade is perpendicular to the fence, as measured with the square. Retighten the three screws. Pay no attention to the reading of the mitre pointer at this point.

Mitre Pointer Adjustment (Fig. A, H)

Unlock mitre lock knob **5** and squeeze the mitre detent latch **6** to move the mitre arm to the zero position. Unlock the mitre lock knob to allow the mitre detent to snap into place as you rotate the mitre arm toward zero. Observe the pointer **23** and mitre scale **7** through the viewing opening shown in Figure H. If the pointer does not indicate exactly zero, loosen the pointer screw, adjust the pointer to 0° and retighten.

Bevel Square to Table (Fig. I, J)

To align the blade square to the rotary table, lock the arm in the down position. Place a square against the blade taking care to not have the square on top of a tooth. Loosen the bevel lock knob **11** so that you can move the bevel arm. Move the bevel arm as necessary so that the blade is at 0° bevel to the table. If the bevel arm needs adjustment, locate the right side bevel stop as shown in Figure J, and adjust the stop screw **28** as necessary.

Bevel Pointer (Fig. J)

If the bevel pointer **30** does not indicate zero, loosen the screw **31** that holds it in place and move the pointer as necessary.

SUGGESTION: For accuracy, set the top edge so that it aligns with zero.

Bevel Stop (Fig. A, J)

To set the 45° bevel stop, first loosen the left side fence lock knob **14** and slide the sliding fence **10** as far as it will go to the left. Move the arm to the left until it stops on the left side bevel stop screw **29**. If the bevel pointer does not indicate exactly 45°, turn the screw downwards. Move the arm to the left and tighten the bevel lock knob **11** firmly when the bevel pointer indicates exactly 45°. Adjust the left side bevel stop screw **29** upwards until it firmly touches the bevel stop.

To achieve 3° right bevel or 48° left bevel, the stop screws must be adjusted to allow the arm to move to the desired location. The bevel stops will need readjustment to the zero and 45° positions after cuts are made.

Fence Adjustment (Fig. K)

WARNING: To reduce the risk of serious personal injury, turn off the tool and disconnect it from the power source before attempting to move it, change accessories or make any adjustments.

To bevel UP TO 48° left, the left side of the fence can be adjusted to the left to provide clearance. To adjust the fence, loosen the fence lock knob **14** and slide the fence to the left. Make a dry run with the saw turned off and check for clearance. Adjust the fence to be as close to the blade as practical to provide maximum workpiece support, without interfering with arm up and down movement. Tighten the fence clamping knob securely. When the bevel operations are complete, don't forget to relocate the fence to the right.

Guard Actuation and Visibility (Fig. L)

CAUTION: Pinch Hazard. To reduce the risk of injury, keep thumb underneath the handle when pulling the handle down. The lower guard will move up as the handle is pulled down which could cause pinching.

The blade guard on your saw has been designed to automatically raise when the arm is brought down and to lower over the blade when the arm is raised.

The guard can be raised by hand when installing or removing saw blades or for inspection of the saw. NEVER RAISE THE BLADE GUARD MANUALLY UNLESS THE SAW IS TURNED OFF.

NOTE: Certain special cuts will require that you manually raise the guard. Refer to **Cutting Large Material** under **Special Cuts**.

The front section of the guard is louvered for visibility while cutting. Although the louvers dramatically reduce flying debris, there are openings in the guard and safety glasses should be worn at all times when viewing through the louvers.

Automatic Electric Brake

Your saw is equipped with an automatic electric blade brake which stops the saw blade within 5 seconds of trigger release. This is not adjustable.

On occasion, there may be a delay after trigger release to brake engagement. On rare occasions, the brake may not engage at all and the blade will coast to a stop.

If a delay or "skipping" occurs, turn the saw on and off 4 or 5 times. If the condition persists, have the tool serviced by an authorised DEWALT service centre.

Always be sure the blade has stopped before removing it from the kerf plate. The brake is not a substitute for guards or for ensuring your own safety by giving the saw your complete attention.

Controls

Your compound mitre saw has several main controls, which will be discussed briefly here. For more information on these controls, see the respective sections later in the manual.

Mitre Control (Fig. A)

The mitre lock knob **5** and mitre detent latch **6** allow you to mitre your saw 50° left and right. To mitre the saw, unlock mitre lock knob **5** by rotating the knob counterclockwise, squeeze the mitre detent latch **6** and set the mitre angle desired on the mitre scale. Lock mitre lock knob by rotating clockwise until tight. Override the mitre detent latch by unlocking the mitre lock knob and pushing the mitre detent override **20** downward. To exit the override, push the mitre detent override switch upward.

Bevel Lock (Fig. J)

The bevel lock knob **11** allows you to bevel the saw 48° left and 3° to the right. To loosen the handle and adjust the bevel setting, turn the handle counterclockwise, the saw head bevels easily to the left. To tighten, turn the handle clockwise. Bevel degree markings are on the bottom front of the saw arm (Fig. H).

Head Downlock Pin (Fig. A)

To lock the saw head in the down position, push the head down, rotate head lock knob **17** 90° and the spring loaded pin will lock in and release the saw head. This will hold the saw head safely down for moving the saw from place to place. To release, pull out the head lock knob and rotate 90°.

OPERATION

Instructions for Use

WARNING: Always observe the safety instructions and applicable regulations.

WARNING: To reduce the risk of serious personal injury, turn tool off and disconnect tool from power source before making any adjustments or removing/installing attachments or accessories. Be sure the trigger switch is in the OFF position. An accidental start-up can cause injury.

Body and Hand Position (Fig. M1–M4)

WARNING: To reduce the risk of serious personal injury, ALWAYS use proper hand position as shown.

WARNING: To reduce the risk of serious personal injury, ALWAYS hold securely in anticipation of a sudden reaction.

Proper positioning of your body and hands when operating the mitre saw will make cutting easier, more accurate and safer. Never place hands near cutting area. Place hands no closer than 152 mm from the blade. Hold the workpiece tightly to the table and the fence when cutting. Keep hands in position until the trigger has been released and the blade has completely stopped. ALWAYS MAKE DRY RUNS (UNPOWERED) BEFORE FINISH CUTS SO THAT YOU CAN CHECK THE PATH OF THE BLADE. DO NOT CROSS ARMS, AS SHOWN IN FIGURE M3. Keep both feet firmly on the floor and maintain proper balance. As you move the mitre arm left and right, follow it and stand slightly to the side of the saw blade. Sight through the guard louvers when following a pencil line.

Trigger Switch (Fig. N)

To turn the saw on, push the lock-off lever **32** to the left, then depress the trigger switch **1**. The saw will run while the switch is depressed. Allow the blade to spin up to full operating speed before making the cut. To turn the saw off, release the switch. Allow the blade to stop before raising the saw head. There is no provision for locking the switch on. A hole **33** is provided in the trigger for insertion of a padlock to lock the switch off.

Always be sure the blade has stopped before removing it from the kerf.

Dust Extraction (Fig. O)

WARNING: To reduce the risk of serious personal injury, turn tool off and disconnect tool from power source before transporting, making any adjustments or removing/installing attachments or accessories. An accidental start-up can cause injury.

WARNING: Certain dust, such as oak or beech dust, is considered carcinogenic, especially in connection with wood-treatment additives.

- Always use dust extraction.
- Provide for good ventilation of the work space.
- It is recommended to wear an appropriate respirator.

CAUTION: Never operate this saw unless the dust bag or DEWALT dust extractor is in place. Wood dust may create a breathing hazard.

CAUTION: Check and clean the dust bag each time after using.

WARNING: When sawing aluminium, remove the dust bag to avoid the risk of fire.

Your mitre saw has a built-in dust port **12** that allows connection to either the supplied dust bag **34**, 35 mm nozzles or direct attachment to the DEWALT AirLock (DWV9000-XJ).

Observe the relevant regulations in your country for the materials to be worked.

To Attach the Dust Bag

1. Fit the dust bag **34** to the dust port **12** as shown in Figure O.

To Empty the Dust Bag

1. Remove dust bag **34** from the saw and gently shake or tap the dust bag to empty.
2. Reattach the dust bag back onto the dust port **12**.

You may notice that all the dust will not come free from the bag. This will not affect cutting performance but will reduce the saw's dust collection efficiency. To restore your saw's dust collection efficiency, depress the spring inside the dust bag when you are emptying it and tap it on the side of the trash can or dust receptacle.

External Dust Extraction (Fig. O)

When vacuuming dry dust that is especially detrimental to health or carcinogenic, use a special dust Class M vacuum cleaner.

Connecting to an AirLock Compatible Dust Extractor (Fig. O)

The dust extractor port **12** on your mitre saw is compatible with the DEWALT AirLock connection system. The AirLock allows for a fast, secure connection between the dust extractor hose **38** and the mitre saw.

1. Ensure the collar on the AirLock connector **39** is in the unlock position. (Refer to Figure O.) Align notches **40** on collar and AirLock connector as shown for unlock and lock positions.
2. Push the AirLock connector onto the dust extractor port **12**.
3. Rotate the collar to the locked position.

NOTE: The ball bearings inside collar lock into slot and secure the connection. The mitre saw is now securely connected to the dust extractor.

Cutting With Your Saw

NOTE: Although this saw will cut wood and many non-ferrous materials, we will limit our discussion to the cutting of wood only. The same guidelines apply to the other materials. **DO**

NOT CUT FERROUS (IRON AND STEEL) MATERIALS OR MASONRY WITH THIS SAW. Do not use any abrasive blades.

Crosscuts (Fig. N)

Cutting of multiple pieces is not recommended but can be done safely by ensuring that each piece is held firmly against the table and fence. A crosscut is made by cutting wood across the grain at any angle. A straight crosscut is made with the mitre arm at the zero degree position. Set the mitre arm at zero, hold the wood on the table and firmly against the fence. Turn on the saw by squeezing the trigger switch shown in Figure N.

When the saw comes up to speed (about 1 second) lower the arm smoothly and slowly to cut through the wood. **Let the blade come to a full stop before raising arm.**

CAUTION: Always use a work clamp to maintain control and reduce the risk of workpiece damage and personal injury.

Mitre crosscuts are made with the mitre arm at some angle other than zero. This angle is often 45° for making corners, but can be set anywhere from zero to 50° left or right. After selecting the desired mitre angle, be sure to tighten the mitre lock knob. Make the cut as described above.

To cut through an existing pencil line on a piece of wood, match the angle as close as possible. Cut the wood a little too long and measure from the pencil line to the cut edge to determine which direction to adjust the mitre angle and recut. This will take some practice, but it is a commonly used technique.

Bevel Cuts (Fig. A)

A bevel cut is a crosscut made with the saw blade at a bevel to the wood. In order to set the bevel, loosen the bevel lock knob **11** and move the saw to the left as desired. (It is necessary to move the left side of the fence to allow clearance). Once the desired bevel angle has been set, tighten the bevel clamp knob firmly.

Bevel angles can be set from 3° right to 48° left and can be cut with the mitre arm set between zero and 50° right or left. Ensure the fence has been adjusted properly. When cutting left bevel, or right mitre compound cuts, it will be necessary to remove the adjustable fence.

Quality of cut

The smoothness of any cut depends on a number of things contributing to the quality of the cut are: material being cut, blade type, blade sharpness and rate of cut all contribute to the quality of the cut.

When smoothest cuts are desired for molding and other precision work, a sharp (60–80 tooth carbide) blade and a slower, even cutting rate will produce the desired results.

Ensure that material does not creep while cutting. Clamp it securely in place. Always let the blade come to a full stop before raising arm.

If small fibers of wood still split out at the rear of the workpiece, apply a piece of masking tape on the wood where the cut will be made. Saw through the tape and carefully remove tape when the cut is finished.

For varied cutting applications, refer to the list of recommended saw blades for your saw and select the one that best fits your needs. Refer to **Saw Blades** under **Optional Accessories** for correct saw blade.

Clamping the Workpiece

WARNING: To reduce the risk of serious personal injury, turn off the tool and disconnect it from the power source before attempting to move it, change accessories or make any adjustments.

WARNING: A workpiece that is clamped, balanced and secure before a cut may become unbalanced after a cut is completed. An unbalanced load may tip the saw or anything the saw is attached to, such as a table or workbench. When making a cut that may become unbalanced, properly support the workpiece and ensure the saw is firmly bolted to a stable surface. Personal injury may occur.

WARNING: The clamp foot must remain clamped above the base of the saw whenever the clamp is used. Always clamp the workpiece to the base of the saw—not to any other part of the work area. Ensure the clamp foot is not clamped on the edge of the base of the saw.

CAUTION: Always use a work clamp to maintain control and reduce the risk of workpiece damage and personal injury.

If you cannot secure the workpiece on the table and against the fence by hand, (irregular shape, etc.) or your hand would be less than 100 mm from the blade, a clamp or other fixture should be used.

For best results use the clamp provided with your saw.

Other aids such as spring clamps, bar clamps or C-clamps may be appropriate for certain sizes and shapes of material. Use care in selecting and placing these clamps. Take time to make a dry run before making the cut. The left fence will slide from side to side to aid in clamping.

To Install Clamp (Fig. A)

1. Insert the clamp into one of the four locations **15** on the base.
2. Lifting up on the arm of the clamp can rapidly adjust the height, then use the fine adjust knob to firmly clamp the workpiece.

NOTE: Place the clamp on the opposite side of the base when beveling. ALWAYS MAKE DRY RUNS (UNPOWERED) BEFORE FINISH CUTS TO CHECK THE PATH OF THE BLADE. ENSURE THE CLAMP DOES NOT INTERFERE WITH THE ACTION OF THE SAW OR GUARDS.

Support for Long Pieces

WARNING: To reduce the risk of serious personal injury, turn off the tool and disconnect it from the power source before attempting to move it, change accessories or make any adjustments.

ALWAYS SUPPORT LONG PIECES.

Never use another person as a substitute for a table extension; as additional support for a workpiece that is longer or wider than the basic mitre saw table or to help feed, support or pull the workpiece.

For best results, use the DWX723, DE7260 or DE7033 mitre saw stand to extend the table width of your saw. This is available from your dealer at extra cost.
Support long workpieces using any convenient means such as sawhorses or similar devices to keep the ends from dropping.

Cutting Picture Frames, Shadow Boxes and Other Four-Sided Projects (Fig. P)

To best understand how to make the items listed here, we suggest that you try a few simple projects using scrap wood until you develop a "FEEL" for your saw.
Your saw is the perfect tool for mitreing corners like the one shown in Figure P. Sketch A in Figure P shows a joint made by using the bevel adjustment to bevel the edges of the two boards at 45° each to produce a 90° mitre corner. For this joint the mitre arm was locked in the zero position and the bevel adjustment was locked at 45°. The wood was positioned with the broad flat side against the table and the narrow edge against the fence. The cut could also be made by mitreing right and left with the broad surface against the fence.

Cutting Trim Molding and Other Frames (Fig. P)

Sketch B in Figure P shows a joint made by setting the mitre arm at 45° to mitre the two boards to form a 90° corner. To make this type of joint, set the bevel adjustment to zero and the mitre arm to 45°. Once again, position the wood with the broad flat side on the table and the narrow edge against the fence.
The two sketches in Figure P are for four sided objects only.
As the number of sides changes, so do the mitre and bevel angles. The chart below gives the proper angles for a variety of shapes. The chart assumes that all sides are of equal length. For a shape that is not shown in the chart, use the following formula. 180° divided by the number of sides equals the mitre or bevel angle.

EXAMPLES

No. Sides	Angle Mitre or Bevel
4	45°
5	36°
6	30°
7	25.7°
8	22.5°
9	20°
10	18°

Cutting Compound Mitres (Fig. Q, R)

A compound mitre is a cut made using a mitre angle and a bevel angle at the same time. This is the type of cut used to make frames or boxes with slanting sides like the one shown in Figure Q.

NOTE: If the cutting angle varies from cut to cut, check that the bevel clamp knob and the mitre lock knob are securely tightened. These knobs must be tightened after making any changes in bevel or mitre.
The chart (Table 1) will assist you in selecting the proper bevel and mitre settings for common compound mitre cuts. To use the chart, select the desired angle "A" (Figure R) of your project and locate that angle on the appropriate arc in the chart. From that point follow the chart straight down to find the correct bevel angle and straight across to find the correct mitre angle.

Set your saw to the prescribed angles and make a few trial cuts. Practice fitting the cut pieces together until you develop a feel for this procedure and feel comfortable with it.

EXAMPLE: To make a 4 sided box with 26° exterior angles (Angle A, Figure R), use the upper right arc. Find 26° on the arc scale. Follow the horizontal intersecting line to either side to get mitre angle setting on saw (42°). Likewise, follow the vertical intersecting line to the top or bottom to get the bevel angle setting on the saw (18°). Always try cuts on a few scrap pieces of wood to verify settings on saw.

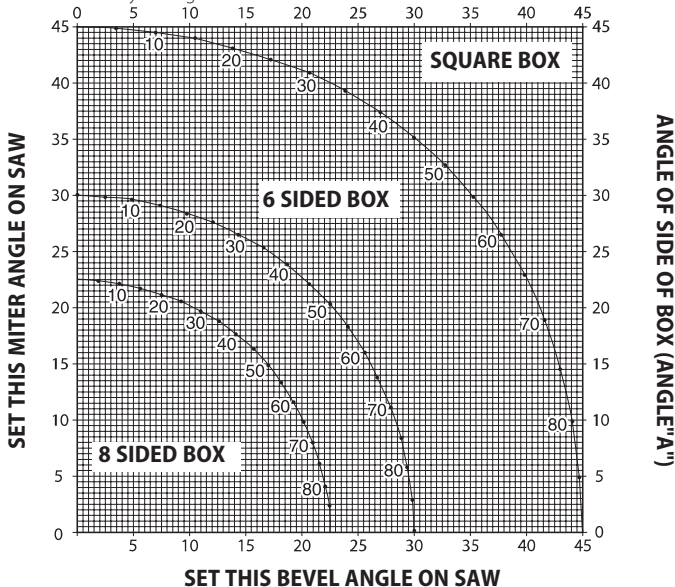

Mitre Scale (Fig. A)

The mitre scale is used when calculating angles. To calculate the proper mitre angle, divide 180° by the number of sides of the box or frame. Refer to **Examples**.

When Mitreing to the Right

To increase the mitre angle when mitreing to the right, move the arm to align the appropriate vernier mark with the closest mark on the mitre scale to the right. To decrease the mitre angle when mitreing to the right, move the arm to align the appropriate vernier mark with the closest mark on the mitre scale to the left.

When Mitreing to the Left

To increase the mitre angle when mitreing to the left, move the arm to align the appropriate vernier mark with the closest mark on the mitre scale to the left. To decrease the mitre angle when mitreing to the left, move the arm to align the appropriate vernier mark with the closest mark on the mitre scale to the right.

Cutting Base Molding

ALWAYS MAKE A DRY RUN WITHOUT POWER BEFORE MAKING ANY CUTS.

Straight 90° Cuts (Fig. S)

Position the wood against the fence as shown in Figure S. Turn on the saw, allow the blade to reach full speed and lower the arm smoothly through the cut.

Cutting Base Molding up to 89 mm High Vertically Against The Fence (Fig. L, S)

Position molding as shown in Figure S.

All cuts are made with the back of the molding against the fence and bottom of the molding against the base.

	Inside corner	Outside corner
Left side	1. Mitre left 45° 2. Save left side of cut	1. Mitre right 45° 2. Save left side of cut
Right side	1. Mitre right 45° 2. Save right side of cut	1. Mitre left 45° 2. Save right side of cut

Material up to 89 mm can be cut as described above. For wider boards [up to 108 mm] several minor concessions must be made.

When cutting a board between 89 mm and 108 mm in width the roller on the tip of the guard could hang up on the workpiece. If this occurs, simply place your right thumb on the upper side of the guard and roll the guard up just enough to clear the workpiece, as shown in Figure L. Once you have cleared the workpiece, you can release the guard and it will continue to open as the cut progresses.

When mitreing to the right side of a base molding wider than 89 mm standing vertically against the fence as in Figure U, the saw can only cut through the board up to 1 inch from the end of the board. Trying to cut more than an inch will cause the saw's gear case to interfere with the workpiece. If you want to cut base molding between 89 mm and 108 mm wide vertically follow the directions below.

Cutting 89 mm–108 mm Base Molding Vertically Against the Fence (Fig. S)

- Position molding as shown in Figure S.
- All cuts made with the back of the molding against the fence.

	Inside corner	Outside corner
Left side*	1. Position molding with bottom of molding against the base of the saw 2. Mitre left 45° 3. Save left side of cut	1. Position molding with bottom of molding against the base of the saw 2. Mitre right 45° 3. Save left side of cut
Right side	1. Position molding with bottom of the molding resting on the base of the saw 2. Mitre right 45° 3. Save right side of cut	1. Position molding with bottom of the molding against the base of the saw 2. Mitre left 45° 3. Save right side of cut

* **NOTE:** If the cut must be made somewhere other than 1" from the end of the molding: cut off the molding at 90° approx. 25.4 mm longer than your final length then make the mitre cut as described above.

Another method of making the cut is to make a zero degree mitre, 45° bevel cut. Your saw can cut a bevel 158 mm wide.

Cutting Base Molding Laying Flat and Using the Bevel Feature

- All cuts made with the saw set at 45° bevel and 0 mitre.
- All cuts made with back of molding laying flat on the saw.
- Move the left side fence out of the path of the blade before attempting any of the following cuts.

	Inside corner	Outside corner
Left side	<ol style="list-style-type: none"> 1. Position molding with top of molding against the fence 2. Save left side of cut 	<ol style="list-style-type: none"> 1. Position molding with bottom of the molding against the fence 2. Save left side of cut
Right side	<ol style="list-style-type: none"> 1. Position molding with bottom of the molding against the fence 2. Save right side of cut 	<ol style="list-style-type: none"> 1. Position molding with top of molding against the fence 2. Save right side of cut

Cutting Crown Molding

Your mitre saw is better suited to the task of cutting crown molding than any tool made. In order to fit properly, crown molding must be compound mitred with extreme accuracy. The two flat surfaces on a given piece of crown molding are at angles that, when added together, equal exactly 90°. Most, but not all, crown molding has a top rear angle (the section that fits flat against the ceiling) of 52° and a bottom rear angle (the part that fits flat against the wall) of 38°.

Your mitre saw has special pre-set mitre detent points at 31.62° left and right for cutting crown molding at the proper angle. There is also a mark on the Bevel scale at 33.85°.

The **Bevel Setting/Type of Cut** chart gives the proper settings for cutting crown molding. (The numbers for the mitre and bevel settings are very precise and are not easy to accurately set on your saw.) Since most rooms do not have angles of precisely 90°, you will have to fine tune your settings anyway.

PRETESTING WITH SCRAP MATERIAL IS EXTREMELY IMPORTANT!

For Cutting Crown Molding Laying Flat and Using the Compound Features (Fig. T)

1. Move the sliding fence **10** out of the path of the blade before attempting any of the following cuts.
2. Molding laying with broad back surface down flat on saw table **36** (Fig. T).

BEVEL SETTING	TYPE OF CUT
33.9°	LEFT SIDE, INSIDE CORNER
	<ol style="list-style-type: none"> 1. Top of molding against fence 2. Mitre table set right 31.6° 3. Save left end of cut
	RIGHT SIDE, INSIDE CORNER
33.9°	<ol style="list-style-type: none"> 1. Bottom of molding against fence 2. Mitre table set left 31.6° 3. Save left end of cut
	LEFT SIDE, OUTSIDE CORNER
	<ol style="list-style-type: none"> 1. Bottom of molding against fence 2. Mitre table set left 31.6° 3. Save right end of cut
33.9°	RIGHT SIDE, OUTSIDE CORNER
	<ol style="list-style-type: none"> 1. Top of molding against fence 2. Mitre table set right 31.6° 3. Save right end of cut

When setting bevel and mitre angles for all compound mitres, remember that: The angles presented for crown moldings are very precise and difficult to set exactly. Since they can easily shift slightly and very few rooms have exactly square corners, all settings should be tested on scrap molding.

PRETESTING WITH SCRAP MATERIAL IS EXTREMELY IMPORTANT!

Alternative Method for Cutting Crown Molding (Fig. U)

Place the molding on the table at an angle between the sliding fence **10** and the saw table **36**, as shown in Figure U. Use of the crown molding fence accessory (DW7084) is highly recommended because of its degree of accuracy and convenience. The crown molding fence accessory is available at extra cost from your local dealer.

The advantage to cutting crown molding using this method is that no bevel cut is required. Minute changes in the mitre angle can be made without affecting the bevel angle. This way, when corners other than 90° are encountered, the saw can be quickly and easily adjusted for them. Use the crown molding fence accessory (DW7084) to maintain the angle at which the molding will be on the wall.

Instructions for Cutting Crown Molding Angled Between the Fence and Base of the Saw for All Cuts (Fig. U)

1. Angle the molding so the bottom of the molding (part which goes against the wall when installed) is against the fence and the top of the molding is resting on the base of the saw, as shown in Figure U.
2. The angled "flats" on the back of the molding must rest squarely on the fence and base of the saw.

	Inside corner	Outside corner
Left side	<ol style="list-style-type: none"> 1. Mitre right 45° 2. Save right side of cut 	<ol style="list-style-type: none"> 1. Mitre left 45° 2. Save right side of cut
Right side	<ol style="list-style-type: none"> 1. Mitre left 45° 2. Save left side of cut 	<ol style="list-style-type: none"> 1. Mitre right 45° 2. Save left side of cut

Special Cuts

NEVER MAKE ANY CUT UNLESS THE MATERIAL IS SECURED ON THE TABLE AND AGAINST THE FENCE.

Aluminum Cutting (Fig. A, V, W)

ALWAYS USE THE APPROPRIATE SAW BLADE MADE ESPECIALLY FOR CUTTING ALUMINUM. These are available at your local DEWALT retailer or DEWALT service centre. Certain workpieces, due to their size, shape or surface finish, may require the use of a clamp or fixture to prevent movement during the cut. Position the material so that you will be cutting the thinnest cross section, as shown in Figure V. Figure W illustrates the wrong way to cut these extrusions. Use a stick wax cutting lubricant when cutting aluminum. Apply the stick wax directly to the saw blade **26** before cutting. Never apply stick wax to a moving blade.

The wax, available at most hardware stores and industrial mill supply houses, provides proper lubrication and keeps chips from adhering to the blade.

Be sure to properly secure workpiece. Refer to **Saw Blades** under **Optional Accessories** for correct saw blade.

Bowed Material (Fig. X, Y)

When cutting bowed material always position it as shown in Figure X and never like that shown in Figure Y. Positioning the material incorrectly will cause it to pinch the blade near the completion of the cut.

Cutting Plastic Pipe or Other Round Material

Plastic pipe can be easily cut with your saw. It should be cut just like wood and **CLAMPED OR HELD FIRMLY TO THE FENCE TO KEEP IT FROM ROLLING**. This is extremely important when making angle cuts.

Cutting Large Material (Fig. L)

Occasionally you will encounter a piece of wood a little too large to fit beneath the blade guard. A little extra height can be gained by rolling the guard up out of the way, as shown in Figure L. Avoid doing this as much as possible, but if need be, the saw will operate properly and make the bigger cut. NEVER TIE, TAPE, OR OTHERWISE HOLD THE GUARD OPEN WHEN OPERATING THIS SAW.

MAINTENANCE

Your DEWALT power tool has been designed to operate over a long period of time with a minimum of maintenance. Continuous satisfactory operation depends upon proper tool care and regular cleaning.

WARNING: To reduce the risk of serious personal injury, turn tool off and disconnect tool from power source before making any adjustments or removing/installing attachments or accessories. Be sure the trigger switch is in the OFF position. An accidental start-up can cause injury.

DO NOT use lubricants or cleaners (particularly spray or aerosol) in the vicinity of the plastic guard. The polycarbonate material used in the guard is subject to attack by certain chemicals.

1. All bearings are sealed. They are lubricated for life and need no further maintenance.
2. Periodically clean all dust and wood chips from around AND UNDER the base and the rotary table. Even though slots are provided to allow debris to pass through, some dust will accumulate.
3. The brushes are designed to give you several years of use. To replace the brushes, return the tool to the nearest service centre for repair. A list of service centre locations is packed with your tool.



Lubrication

Your power tool requires no additional lubrication.



Cleaning

WARNING: Blow dirt and dust out of the main housing with dry air as often as dirt is seen collecting in and around the air vents. Wear approved eye protection and approved dust mask when performing this procedure.

WARNING: Never use solvents or other harsh chemicals for cleaning the non-metallic parts of the tool. These chemicals may weaken the materials used in these parts. Use a cloth dampened only with water and mild soap. Never let any liquid get inside the tool; never immerse any part of the tool into a liquid.

Optional Accessories

WARNING: Since accessories, other than those offered by DEWALT, have not been tested with this product, use of such accessories with this tool could be hazardous. To reduce the risk of injury, only DEWALT recommended accessories should be used with this product.

Consult your dealer for further information on the appropriate accessories.

The following accessories, designed for your saw, may be helpful. In some cases, other locally obtained work supports, length stops, clamps, etc., may be more appropriate. Use care in selecting and using accessories.

The following accessories, designed for your saw, may be helpful. In some cases, other locally obtained work supports, length stops, clamps, etc., may be more appropriate. Use care in selecting and using accessories.

Adjustable Length Stop: DW7051

Requires the use of one work support. It is used to make repetitive cuts of the same length from 0 to 107 cm.

Clamp: DW7082

Used for firmly clamping workpiece to the saw fence for precision cutting.

Dust Bag: DW7053**Included with some models**

Equipped with a zipper for easy emptying, the dust bag will capture the majority of the sawdust produced.

Crown Molding Fence: DW7084

Used for precision cutting of crown molding.

Mitre Saw Stands: DWX723, DE7260, DE7033

Provides stable and accurate work platform for mitre saws.

Saw Blades

ALWAYS USE 254 mm SAW BLADES WITH 16 mm ARBOUR HOLES. SPEED RATING MUST BE AT LEAST 5500 RPM. Never use a smaller diameter blade. It will not be guarded properly. Use crosscut blades only! Do not use blades designed for ripping, combination blades or blades with hook angles in excess of 7 degrees.

BLADE DESCRIPTIONS		
APPLICATION	DIAMETER	TEETH
Construction Saw Blades (thin kerf with anti-stick rim)		
General Purpose	254 mm	40
Fine Crosscuts	254 mm	60
Woodworking Saw Blades (provide smooth, clean cuts)		
Fine crosscuts	254 mm	80
Non-ferrous metals	254 mm	80
NOTE: For cutting non-ferrous metals, use only saw blades with TCG teeth designed for this purpose.		

Protecting the Environment

Separate collection. Products and batteries marked with this symbol must not be disposed of with normal household waste.

Products and batteries contain materials that can be recovered or recycled reducing the demand for raw materials. Please recycle electrical products and batteries according to local provisions. Further information is available at www.2helpU.com.

Troubleshooting Guide**BE SURE TO FOLLOW SAFETY RULES AND INSTRUCTIONS**

TROUBLE!	WHAT'S WRONG?	WHAT TO DO
Saw will not start	Saw not plugged in	Plug in saw.
	Fuse blown or circuit breaker tripped	Replace fuse or reset circuit breaker.
	Cord damaged	Have cord replaced by authorised service centre.
	Brushes worn out	Have brushes replaced by authorised service centre or replace them yourself.
Saw makes unsatisfactory cuts	Dull blade	Replace blade. Refer to Changing or Installing a New Saw Blade .
	Blade mounted backwards	Turn blade around. Refer to Changing or Installing a New Saw Blade .
	Gum or pitch on blade	Remove blade and clean with turpentine and coarse steel wool or household oven cleaner.
	Incorrect blade for work being done	Change the blade type. Refer to Saw Blades under Accessories .
Blade does not come up to speed	Extension cord too light or too long	Replace with adequate size cord. Refer to Additional Safety Rules for Mitre Saws .
	Low house current	Contact your electric company.
Machine vibrates excessively	Saw not mounted securely to stand or work bench	Tighten all mounting hardware. Refer to Bench Mounting .
	Stand or bench on uneven floor	Reposition on flat level surface. Refer to Familiarization .
	Damaged saw blade	Replace blade. Refer to Changing or Installing a New Saw Blade .
Does not make accurate mitre cuts	Mitre scale not adjusted correctly	Check and adjust. Refer to Mitre Scale Adjustment under Assembly and Adjustments .
	Blade is not square to fence	Check and adjust. Refer to Mitre Scale Adjustment under Assembly and Adjustments .
	Blade is not perpendicular to table	Check and adjust fence. Refer to Bevel Square to Table under Assembly and Adjustments .
	Workpiece moving	Clamp workpiece securely to fence or glue 120 grit sandpaper to fence with rubber cement.
Material pinches blade	Cutting bowed material	Refer to Bowed Material under Special Cuts .

Belgique et Luxembourg België en Luxemburg	DeWALT - Belgium BVBA Egide Walschaertsstraat 16 2800 Mechelen	Tel: NL 32 15 47 37 63 Tel: FR 32 15 47 37 64 Fax: 32 15 47 37 99	www.dewalt.be enduser.BE@sbdinc.com
Danmark	DeWALT (Stanley Black&Decker AS) Roskildevej 22 2620 Albertslund	Tel: 70 20 15 10 Fax: 70 22 49 10	www.dewalt.dk kundeservice.dk@sbdinc.com
Deutschland	DeWALT Richard Klinger Str. 11 65510 Idstein	Tel: 06126-21-0 Fax: 06126-21-2770	www.dewalt.de infodwge@sbdinc.com
Ελλάς	DeWALT (Ελλάς) A.E. ΕΔΡΑ-ΓΡΑΦΕΙΑ : Στρόβιλος 7 & Λ. Βουλιαγμένης, Γλυφάδα 166 74, Αθήνα SERVICE : Ημέρος Τόπος 2 (Χάνι Αδάμ) – 193 00 Ασπρόπυργος	Τηλ: 00302108981616 Φαξ: 00302108983570	www.dewalt.gr Greece.Service@sbdinc.com
España	DeWALT Ibérica, S.C.A. Parc de Negocios "Mas Blau" Edificio Muntadas, c/Bergadá, 1, Of. A6 08820 El Prat de Llobregat (Barcelona)	Tel: 934 797 400 Fax: 934 797 419	www.dewalt.es respuesta.postventa@sbdinc.com
France	DeWALT (Stanley Black & Decker France SAS) 62 Chemin de la Bruyère CS 60105, 69574 DARDILLY Cedex	Tel: 04 72 20 39 20 Fax: 04 72 20 39 00	www.dewalt.fr scufr@sbdinc.com
Schweiz Suisse Svizzera	DeWALT In der Luberzen 42 8902 Urdorf	Tel: 044 - 755 60 70 Fax: 044 - 730 70 67	www.dewalt.ch service@rofoag.ch
Ireland	DeWALT Building 4500, Kinsale Road Cork Airport Business Park Cork, Ireland	Tel: 00353-2781800 Fax: 01278 1811	www.dewalt.ie Sales.Ireland@sbdinc.com
Italia	DeWALT via EnergyPark 6 20871 Vimercate (MB), IT	Tel: 800-014353 39 039-9590200 Fax: 39 039-9590311	www.dewalt.it
Nederlands	DeWALT Netherlands BVPostbus 83, 6120 AB BORN	Tel: 31 164 283 063 Fax: 31 164 283 200	www.dewalt.nl
Norge	DeWALT Postboks 4613 0405 Oslo, Norge	Tel: 45 25 13 00 Fax: 45 25 08 00	www.dewalt.no kundeservice.no@sbdinc.com
Österreich	DeWALT Werkzeug Vertriebsges m.b.H Oberlaaerstrasse 248, A-1230 Wien	Tel: 01 - 66116 - 0 Fax: 01 - 66116 - 614	www.dewalt.at service.austria@sbdinc.com
Portugal	DeWALT Ed. D Dinis, Quina da Fonte Rua dos Malhoes 2 - 2A 2º Esq. Oeiras e S. Juliao da Barra, paço de Arcos e Caxias 2770 071 Paço de Arcos	Tel: +351 214667500 Fax: +351214667580	www.dewalt.pt resposta.posvenda@sbdinc.com
Suomi	DeWALT PL47 00521 Helsinki, Suomi	Puh: 010 400 4333 Faksi: 0800 411 340	www.dewalt.fi asiakaspalvelu.fi@sbdinc.com
Sverige	DeWALT BOX 94 43122 Mölndal Sverige	Tel: 031 68 61 60 Fax: 031 68 60 08	www.dewalt.se kundeservice.se@sbdinc.com
Türkiye	Sanayi ve Ticaret Bakanlığı tebliğince kullanım ömrü 7 yıldır. Stanley Black & Decker Turkey Alet Üretim San. Tic. Ltd.Şti. Kozyatağı Mh Değirmen Sk. Nida Kule No: 18 Kat: 6, 34742 Kadıköy, İstanbul, Türkiye	Tel: +90 216 665 2900 Faks: +90 216 665 2901	www.dewalt.com.tr info-tr@sbdinc.com
United Kingdom	DeWALT, 210 Bath Road; Slough, Berks SL1 3YD	Tel: 01753-567055 Fax: 01753-572112	www.dewalt.co.uk emeaservice@sbdinc.com
Australia	DeWALT 810 Whitehorse Road Box Hill VIC 3128 Australia	Tel: Aust 1800 338 002 Tel: NZ 0800 339 258	www.dewalt.com.au www.dewalt.co.nz
Middle East Africa	DeWALT P.O. Box - 17164, Jebel Ali Free Zone (South), Dubai, UAE	Tel: 971 4 812 7400 Fax: 971 4 2822765	www.dewalt.ae Service.MEA@sbdinc.com